

IZZY WATSON

Part 1 Architectural Designer, Educator & Fabricator

Detailed portfolio www.izzywatson.co.uk

I am an energetic & industrious 26 year old with a spectrum of experience in industry as well as in personally driven projects. I have a detailed understanding of materials & to-scale construction methods and am a keen model maker & visual story teller. I'm particularly interested in design for the public realm and inclusive community engagement. Keen to work in a team with like minded and inspiring colleagues, I can progress through tasks independently as well as with ease collaboratively.

Employment

Exhibition Designer & Production • UCL MEng • Jun - Nov 2024

- Design of exhibition layout & plinths/display pieces to support an installation by the professors of the MEng Architectural design programme at UCL.
- Production of all exhibition elements, using a wide range of metal & wood working tools & machinery including welding & lathing, in the HERE EAST UCL workshop.
- Collaborating with a team comprised of academics, recent graduates & technicians
- Correspondance & collaboration with curators & associates of a world renowned architectural institution, throughout design and production, as well as during install/deinstall & the shows duration.

Programme designer & Teacher • Urban Learners • Jan 2024-Present

- Design & execution of architectural education programmes, clients include Grimshaw Foundation, Camden Highline & The Museum of Brutalist Architecture.
- Producing guides, instructions and presentations to communicate with school students, adult volunteers & clients
- Extreme sport problem solving, for example the start to finish execution of 160 students designing & building 8 installations from a bespoke toolbox of cardboard boxes, tubes, string etc. including extensive structural design & innovative detailing to realise their designs from conceptualisation, through 1:10 models, to final build.

Studio & Workshop Assistant • Boano Prismontas • Jan 2024-Present

- Design, in-house fabrication & on-site instal of small scale architectural projects
- Model making & proposal visualisation

Workshop Assistant • James Capper Sculpture • Jun 2023-Jan 2024

- Welding & metal work, fabricating & finishing sculptures to a very high standard
- Contributing to evolving designs, tackling logistics of kinetic sculptures
- Working to deadlines, attracting new business, streamlining the workshop space

Designer/Fabricator/Visualiser/PA • Studio Wilson-Copp • Apr-May 2022

- Assisting design & fabrication of bespoke timber & metal furniture & interior fittings
- Sketching, model making & CAD for communicating ideas with the team & to clients
- Management of all online platforms & promotion
- Leasing with clients & subcontractors both online & in person
- General organisation & running of the business including invoicing & scheduling

Architectural Designer • Owen Architects • Jul-Aug 2019 & Sept-Apr 2022

- Prepared full 3D site models. Technical drawings & other visual representations of existing & proposed structures, including renderings, physical models and collage
- Laying out proposals, presentations & competition entry documentation, compiling information & graphics from across the studio team.
- Developed architectural strategies, presenting outcomes to management & peers.
- Compiling planning proposals, including archival research on listed buildings.
- Prepared models for 3D printing.

Education

BSc Architecture • The Bartlett School of Architecture • 2019-2023

First Class Honors

- Chosen by my unit peers as lead fabricator during our graduation show build & resultantly co-lead & organised the 12 person team through a highly pressurised & constrained design & install of a very ambitious gallery space which showcased our work both as a collective & as accomplished individual designers, utilising material, lighting & meticulous curation.
- During first year I was chosen by our tutors to lead our installation design group project, as well as taking on the role of Unit 0 student representative in second year.

BSc Biochemistry • University of Manchester • 2017-2019

- Completed 4 terms of BSc Biochemistry averaging a 2:1, gaining a CertHE before leaving to pursue more creative endeavors.

Foundation Diploma in Art & Design • Kingston University • 2016-2017

Distinction

- Specialised in fashion & textiles, an interest which I have maintained as a hobby & has influenced my design process specifically with regard to facade & material design.

Exhibitions

Curator & Producer • Furniture & Functional Objects • Jun 2024

CASTLE • London

- Curation & production of group show, featuring the work of 13 artists & makers.
- Full graphic design package & distribution.
- Total revamp of roadside shop into a gallery space.

Exhibiting Artist • Formworks Collective - A New Atavism • Sept 2024

Greatorex Street • London

- Bespoke sculpture / installation. Installed on site using adaptable and non invasive attachment methods.

Exhibition Designer & Production • In(Visible) Energies • Nov 2024

Mies Van der Rohe Pavilion • Barcelona

- Design, layout, full fabrication & on site installation of all exhibition structures. To support an installation engineered by UCL Here East research team.

Plans & Projects

- Professionally life modelling for individual artists & regular classes. Institutions include Lauderdale House and Royal Academy of Arts.
- Making jewelry, unique functional objects & furniture from home & with access to an extensive workshop.

Contact

SE London

+44 753 209 5016

hello@izzywatson.co.uk

Software

Adobe Suite



Rhino



Sketchup



V-Ray



Blender



Microstation



Word & Excel



Laser cutting



CNC



Metal/Welding



Wood/Carpentry



References

Venetia Woolf

Urban Learners

venetia@urbanlearners.org

+44 794 975 4942

James Capper

James Capper Sculpture

jamescapper.sculpture@gmail.com

+44 779 046 6656

Huw Owen

Owen Architects

Huw.owen@owenarchitects.co.uk

+44 795 736 4375

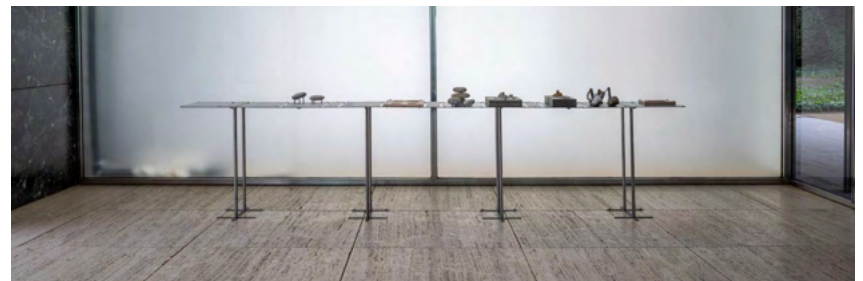
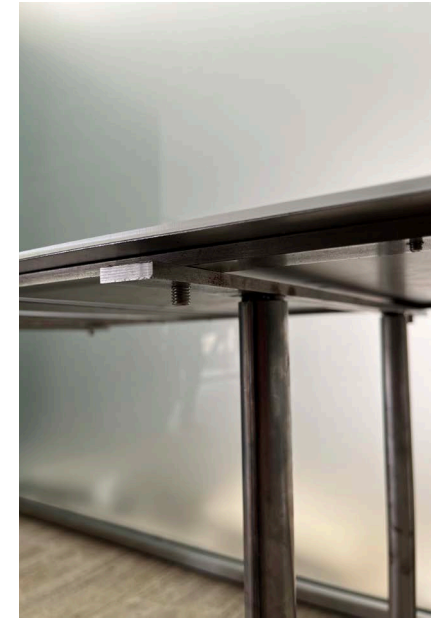
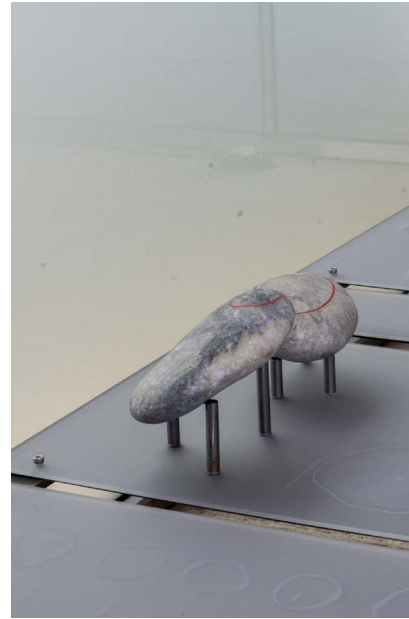

In(Visible) Energies - Exhibition design - November 2024

Exhibition design and production to support an installation engineered by UCL Here East research team.

Everything is threaded - each of the different structures requiring no nuts, held together and given rigidity by the display items themselves. This idea references the manufacturing and structural system of the pebble stacks and stems from the importance of connection details in these sculptures.

The other main design driver was the site itself, particularly concerned with the interaction between the stands and the gridded travertine. I wanted to use the gaps between and the void below to give the spindly structures stability, as well as hiding electrics and defining location.



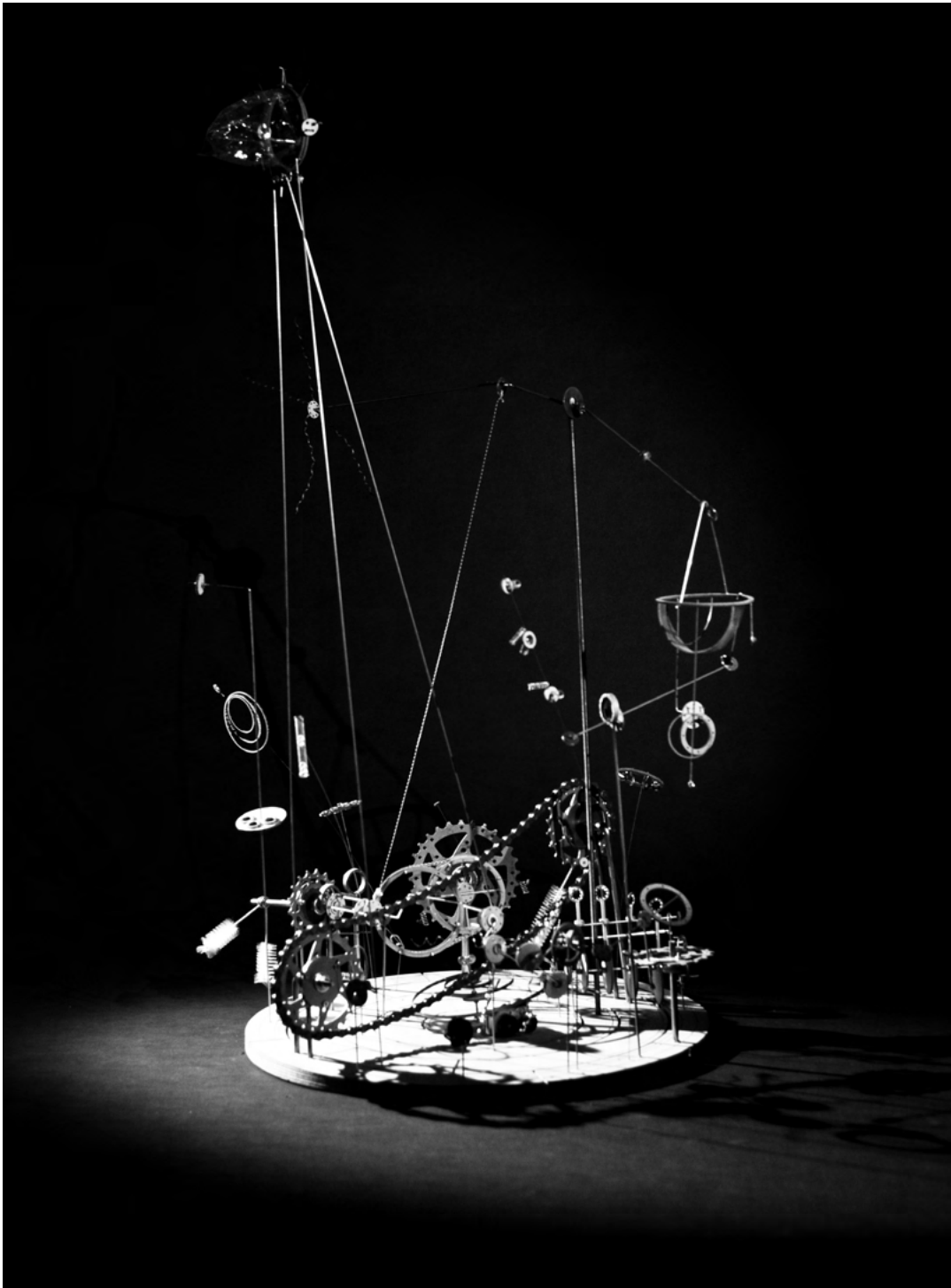

1:10 Model of Kinetic Installation Proposal & Communal Living Research Collage - Thesis Project 2023

1:10 scale model of a site specific wind powered installation. Inspired by the motion and form of agricultural machinery and our growing dependence on it, the components lurch, swing and rotate through a series of interconnected mechanical pathways.

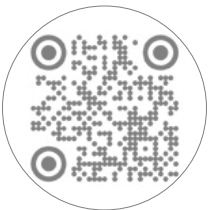
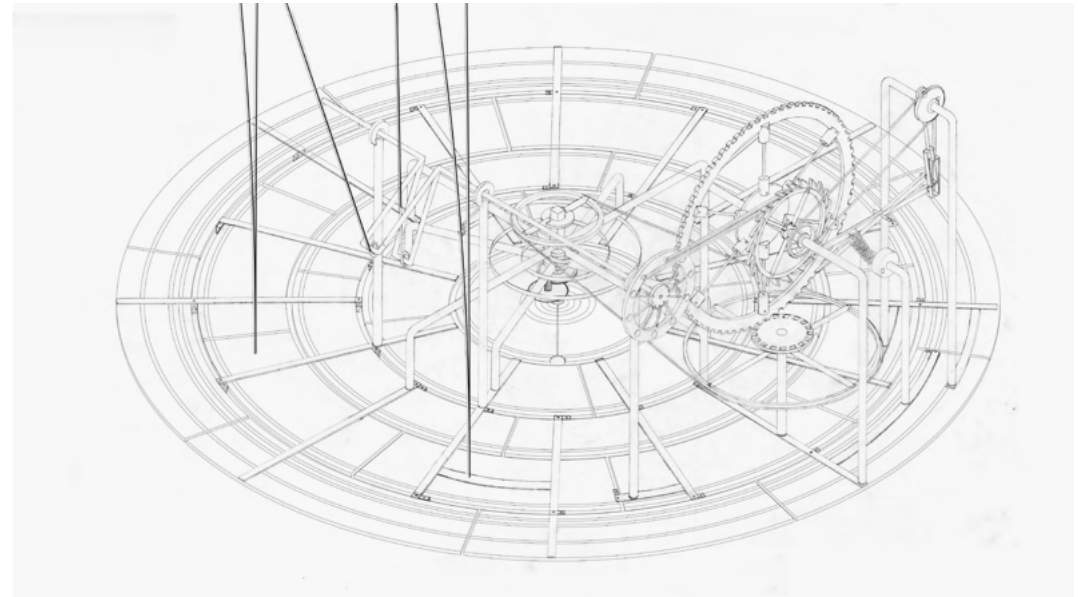
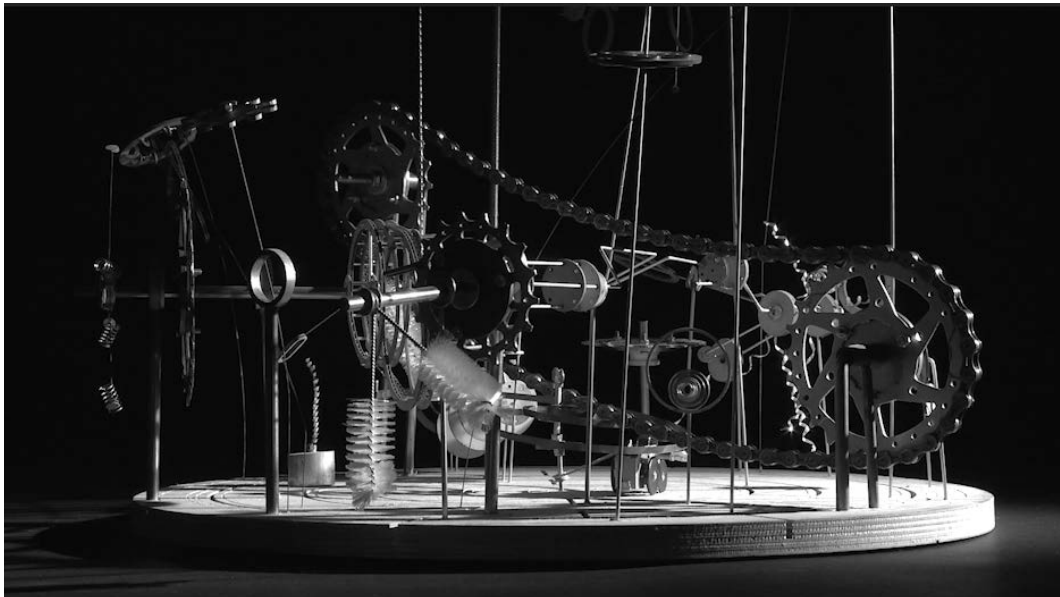
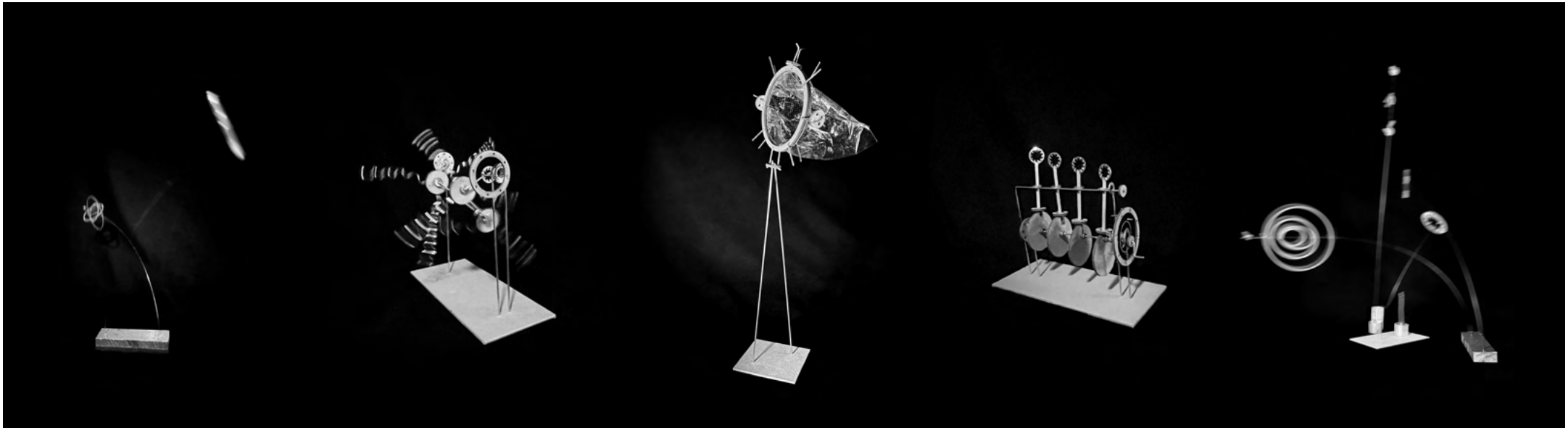

Video of 1:10 model in motion - 2023

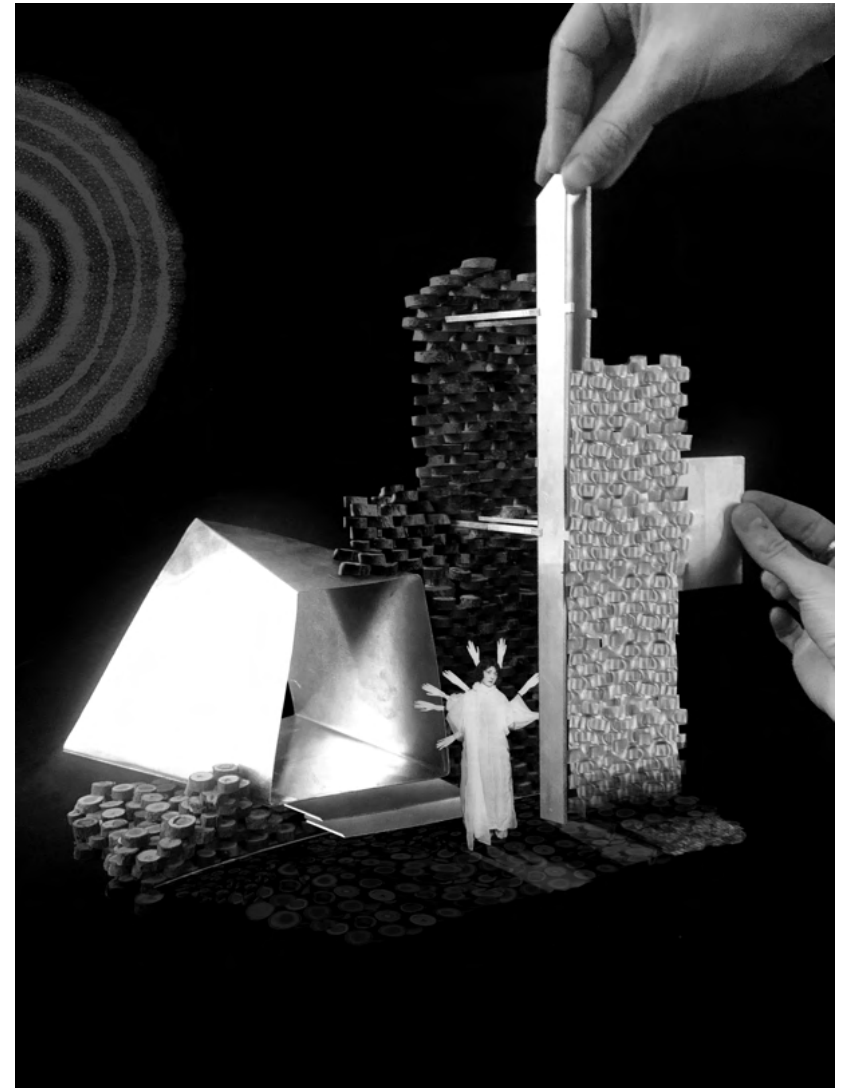
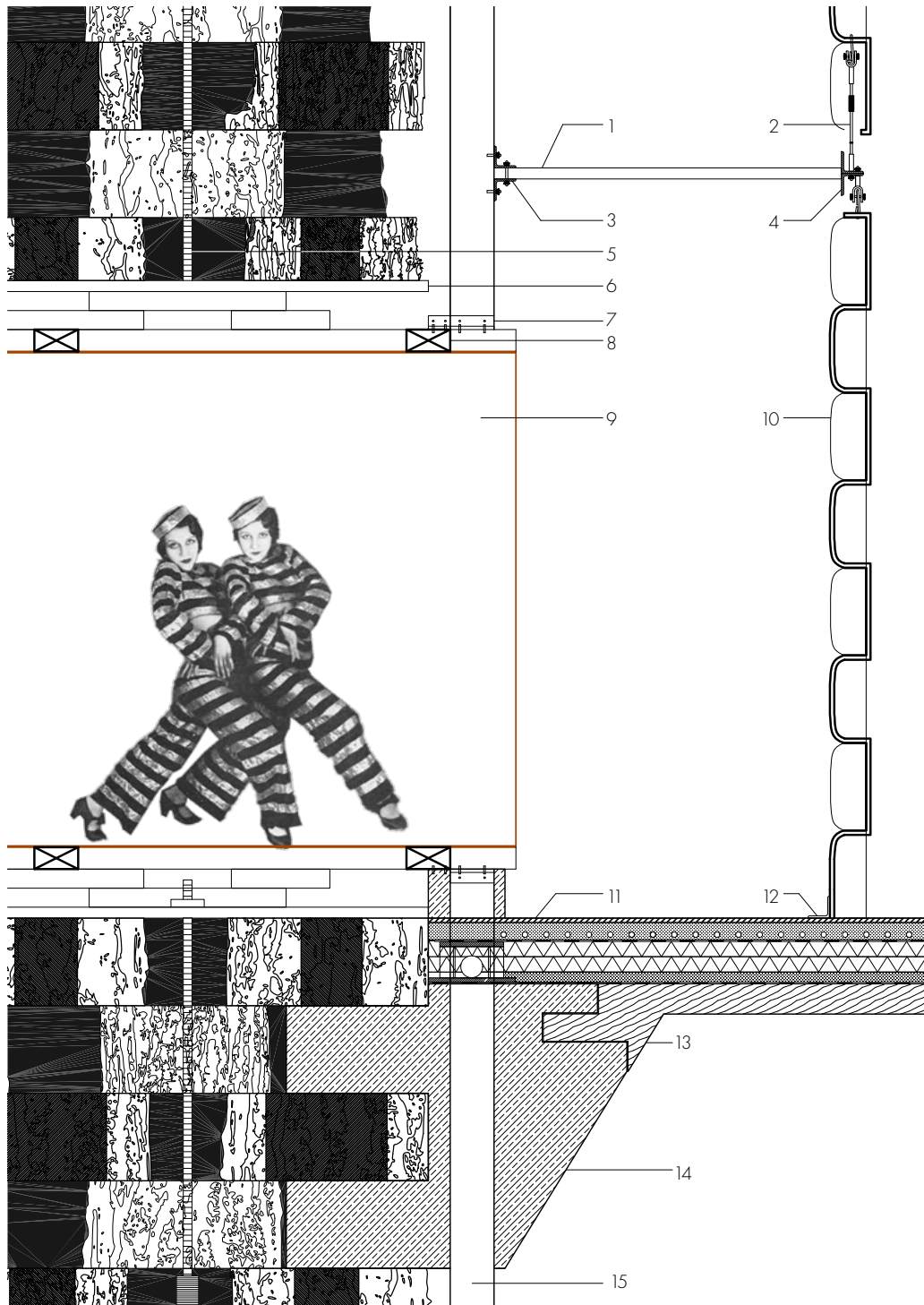

Material build up technical detail & accompanying collage - Thesis Project 2023

The project was explored mainly through collage & model making with a strong focus on material design in relation to light. I was considerate of representing different material build-ups at scale using unexpected materials. For example post tensioning sections of logs to make a dense & insulating core wall using meticulously stacked sectioned sticks.

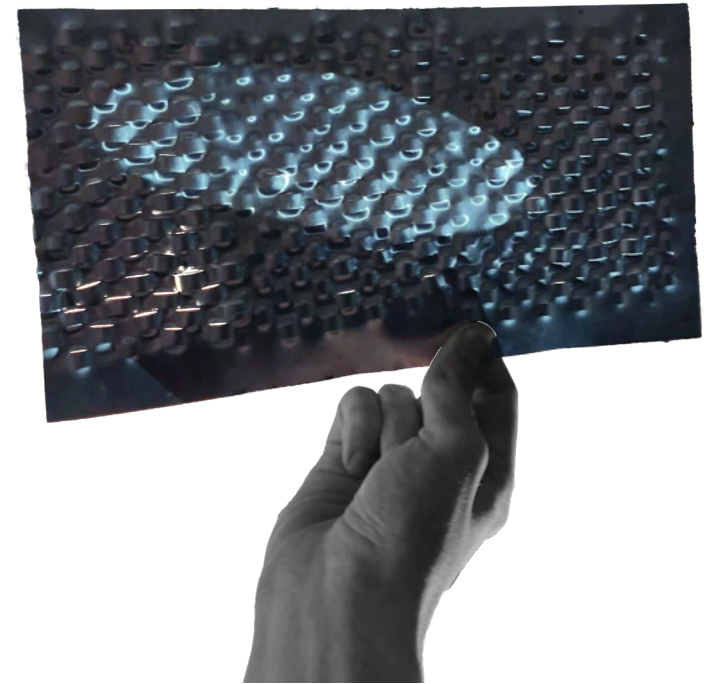
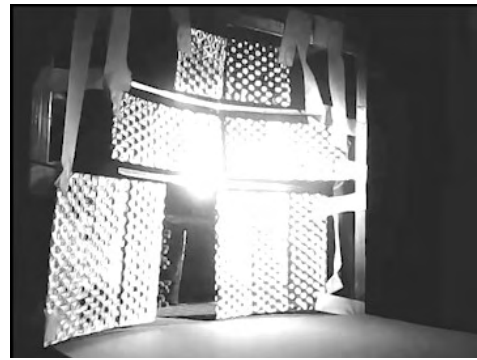
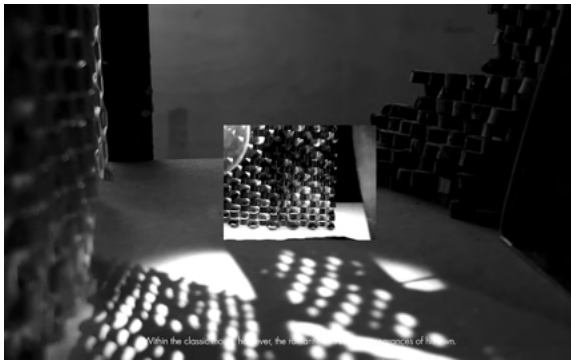
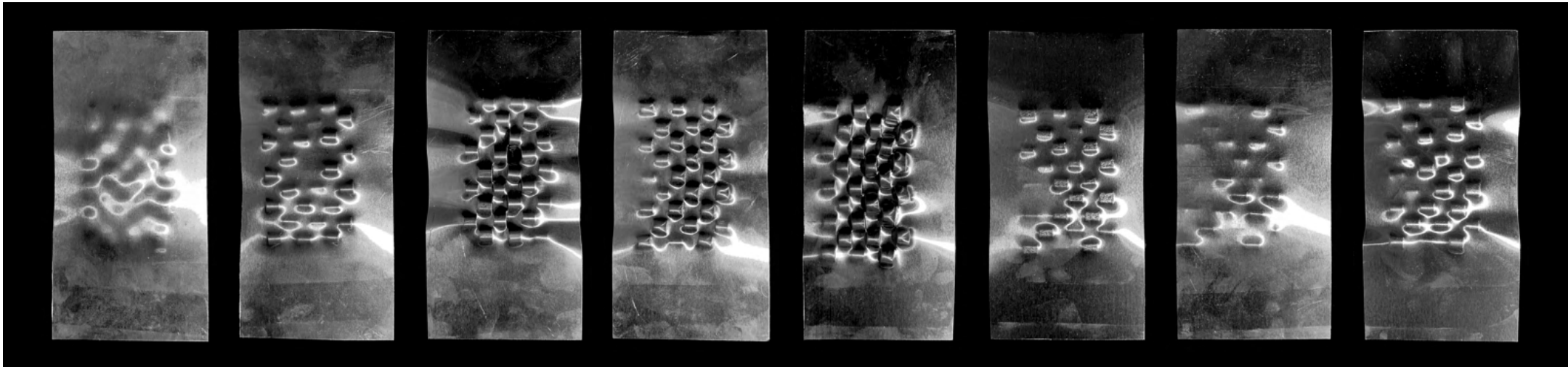

Material development - Thesis Project 2023

One of the main features of my building design was the textiles made of pressed aluminium. I produced a series of samples my experimenting with varying the density & compressibility of materials, the forms I was taking a relief of & the pressure exerted by the hydraulic press. I then experimented with how to tile the process in order to make larger seamless pieces of the permeable imprinted metal.

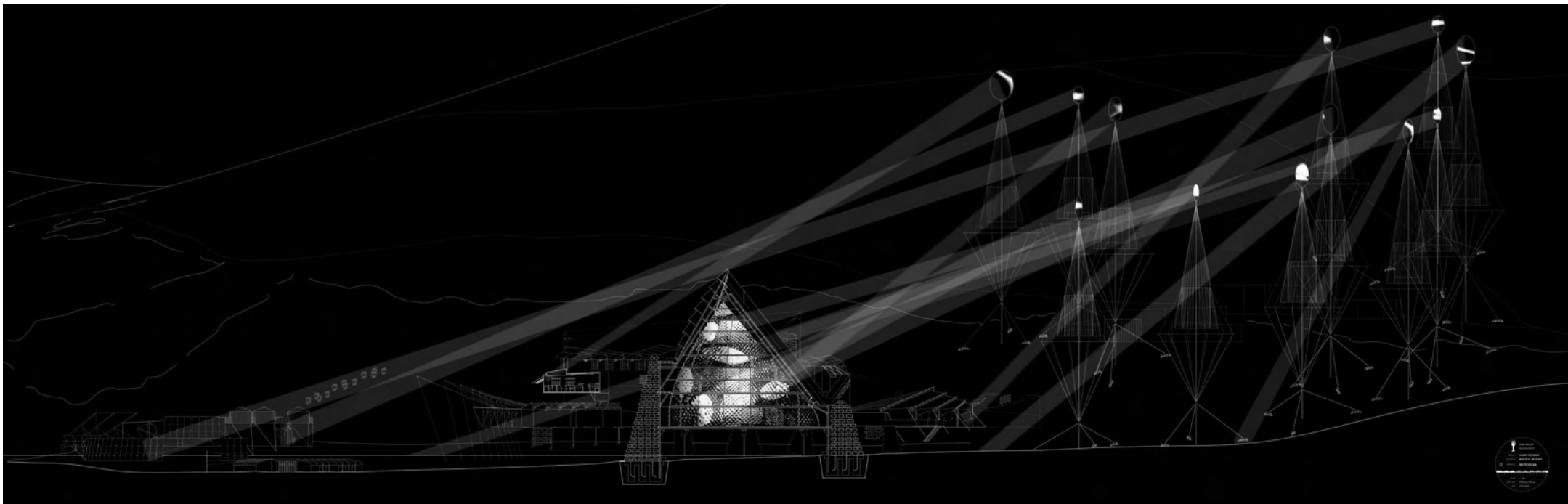
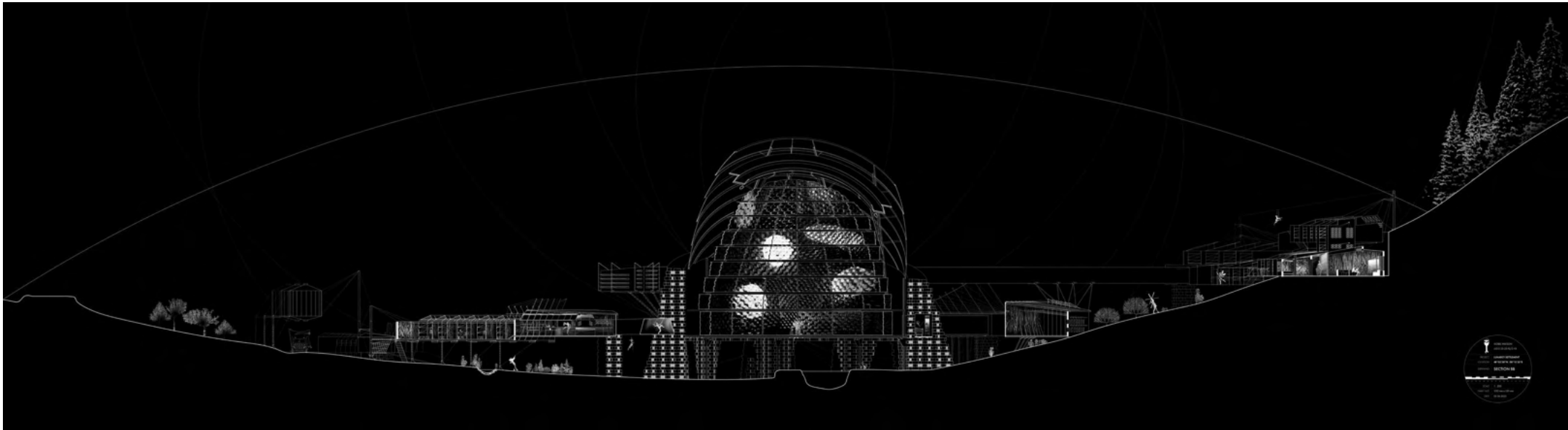

Sectional Drawings of Final Building Proposal - Thesis Project 2023

Set in a valley in the Black Forest, this farming commune shares a deep rooted obsession with the moon and the continuous geometry of circles, fundamental to mechanistic pathways. Premised on the relationship between man and mechanism, the building is a collection of anthropomorphic machines which are maintained, expanded and worshipped by its inhabitants, a mix of 'romantic' minds (concerned with aesthetic and overall form) and 'classical' minds (concerned with the function of individual parts composing the whole). Towering mirror machines target circular moonlight towards the site, controlling work and play on the farm. These drawings are each 3m long.

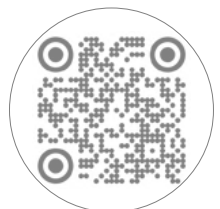
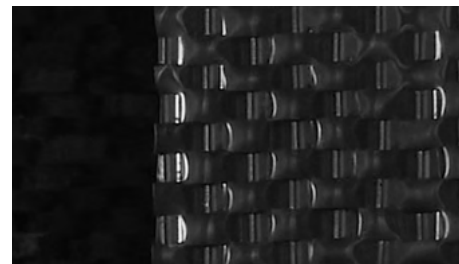
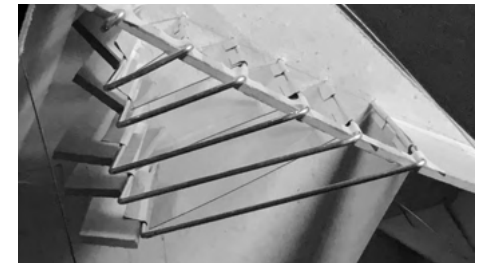
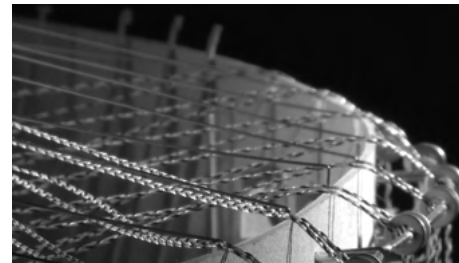
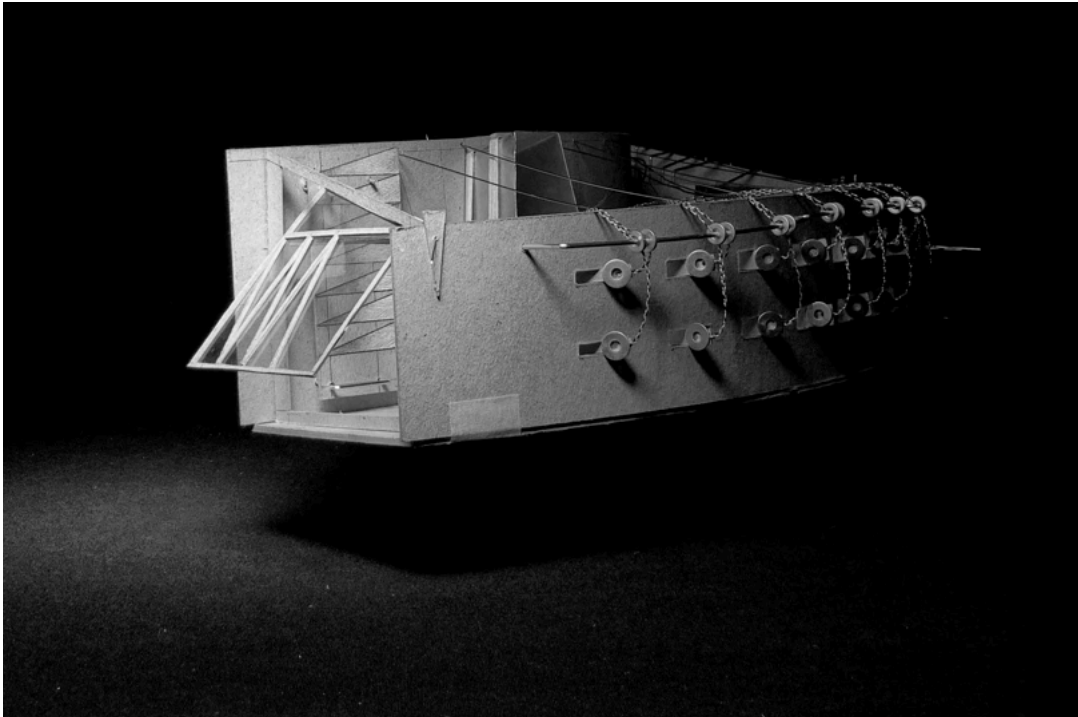

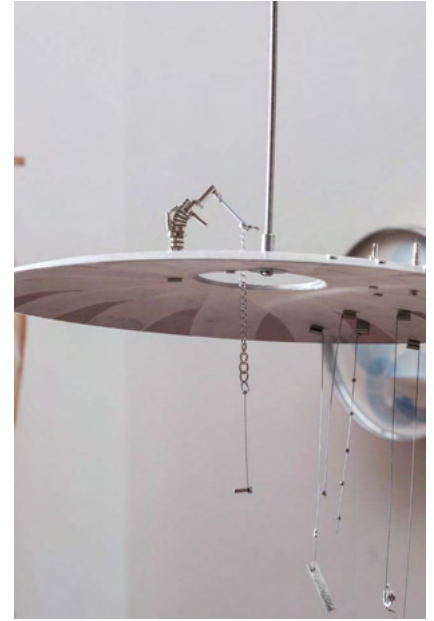

Formworks Collective : A New Atavism - September 2024

Sculpture for FormWorks Collective's exhibition 'A New Atavism'

Images courtesy of @lucascoombsfilms and @jacobsirkin

form works

**GREATOREX
STREET**



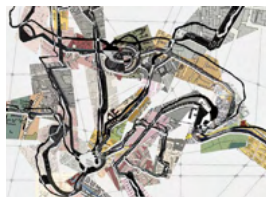
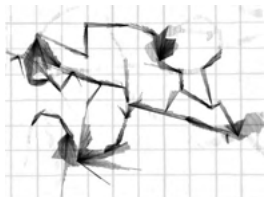
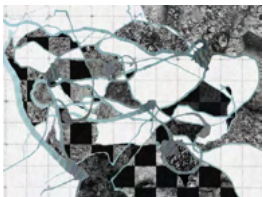
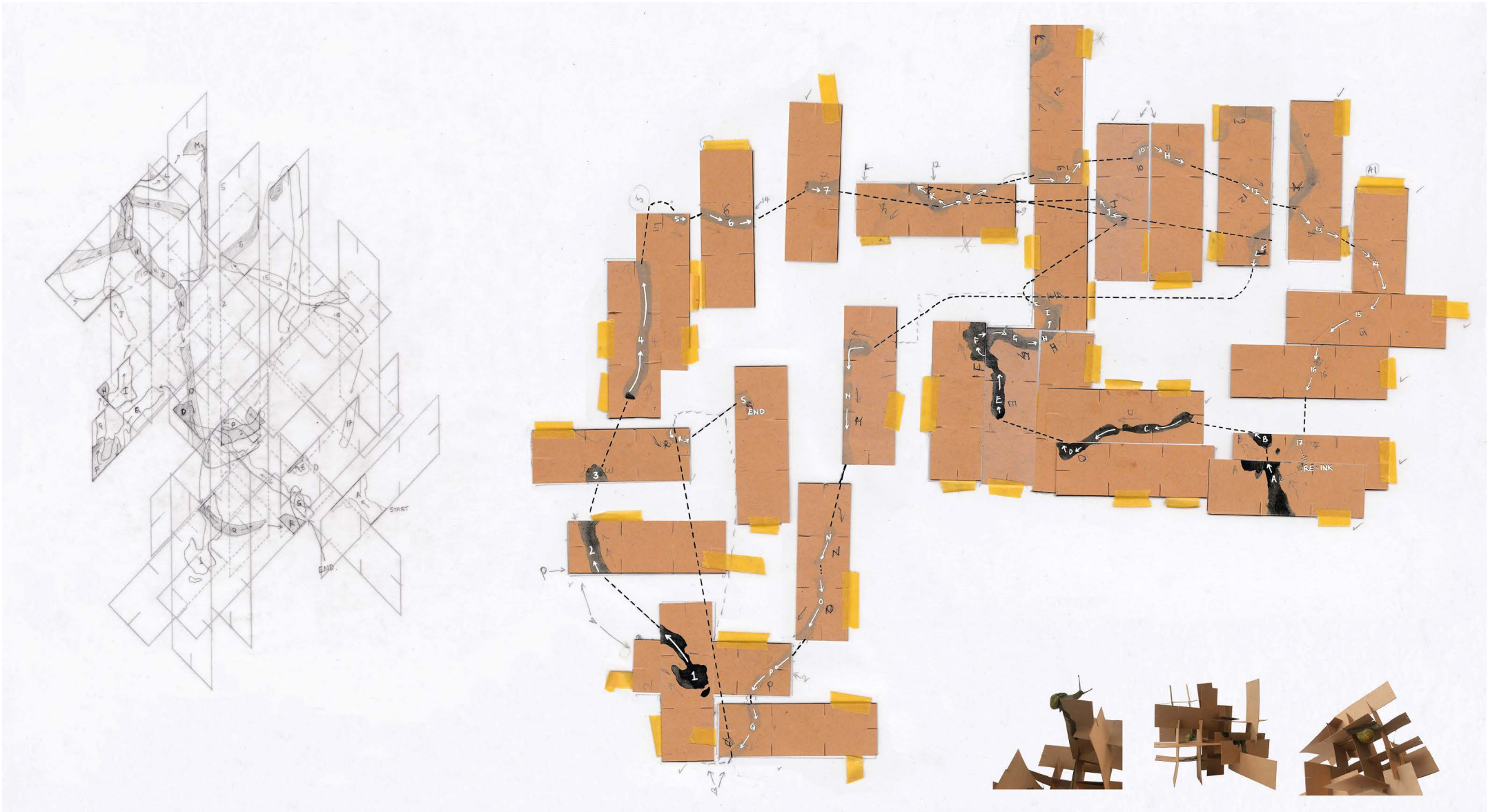

'In View of Situations' - Collages - 2021

Developed from the theories of the Situationist International and their favoured practice of psychogeography, this project challenges our modern-day approach to how we travel around cities like London. The masterplan aims to centre the spirit of urban exploration, and of wandering without purpose, in order to reclaim the city rather than simply adhering to the usual pattern of travelling between home-work-commerce. This puts the act of observing the built environment and the city's inhabitants at the forefront of people's minds as they continue their daily lives amid the urban landscape.

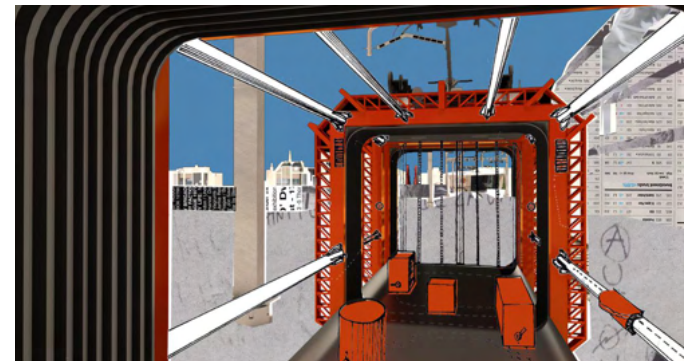
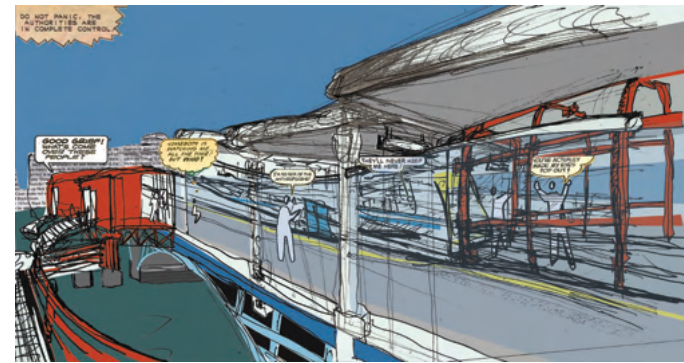
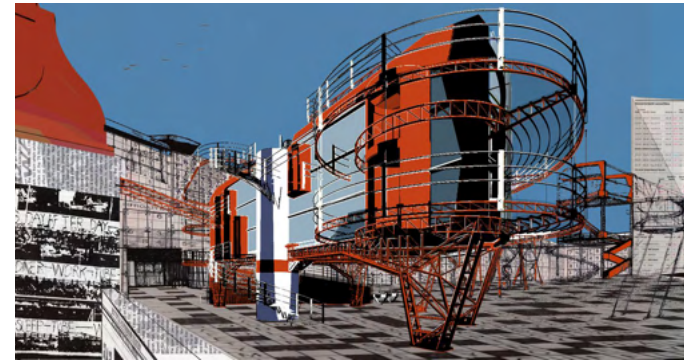
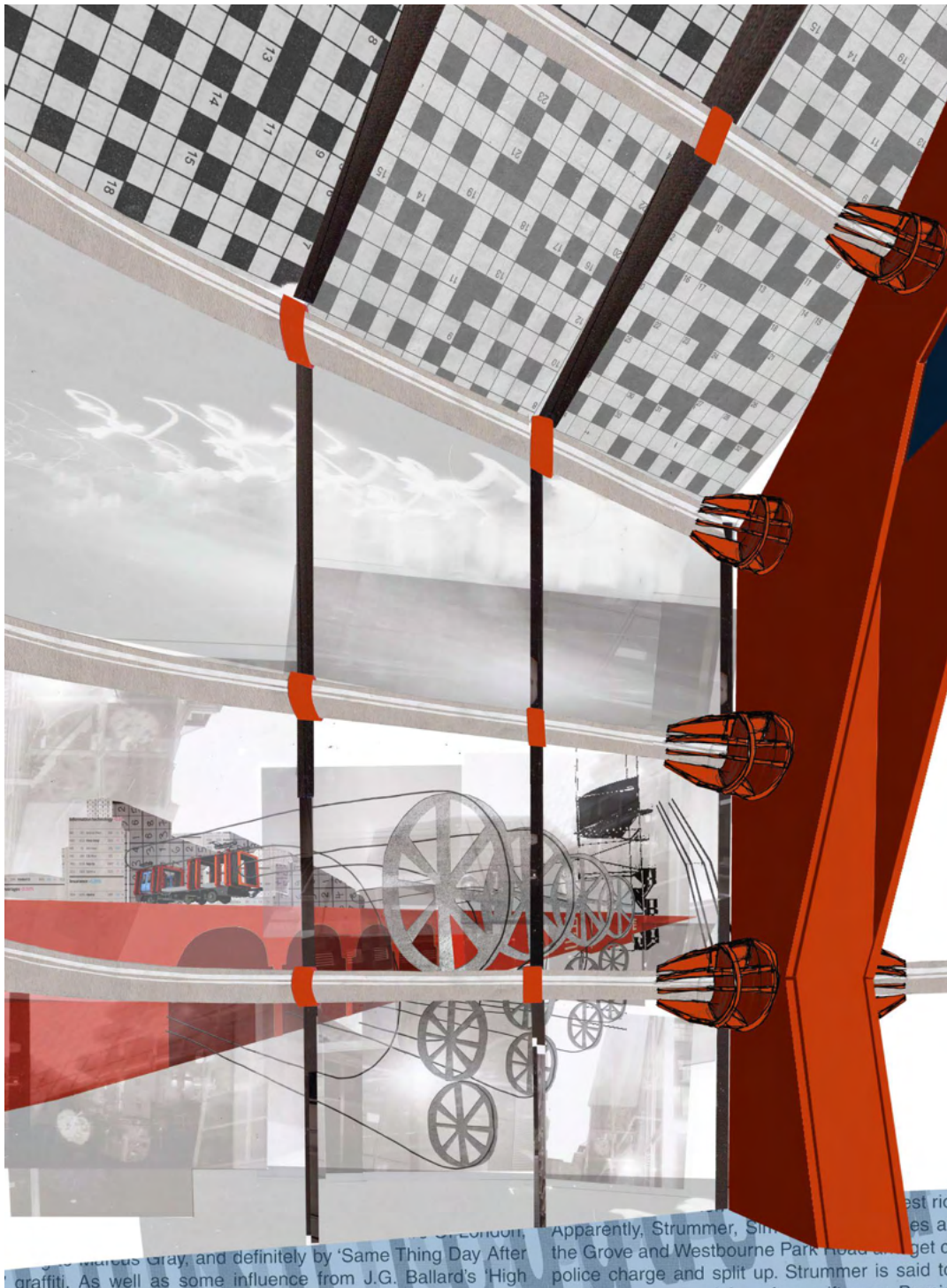

'In View of Situations' - Building Proposal Collages - 2021

Located beside Blackfriars Station on the Southbank, the building provides a sprawling free public space, art studios, practice spaces, waiting rooms and a docking station. Large symbiotic mechanisms attach observatory modules to trains as they arrive at Blackfriars Station, and flaneur passengers are taken on a derive through the city. A diverse range of interlinked conditions within the scheme cater to preferences for exhibitionism and voyeurism, pause and exploration.

Altogether this creates a labyrinth of liminal and activatable spaces, promoting observation of not only its own articulated structure and its surrounding environments but also—and perhaps more importantly—of visitors, onlookers, and their varied activities.

All collage material is taken from situationist magazines, video games that encourage world mapping, anarchist comics and newspaper games from my own travels around London.

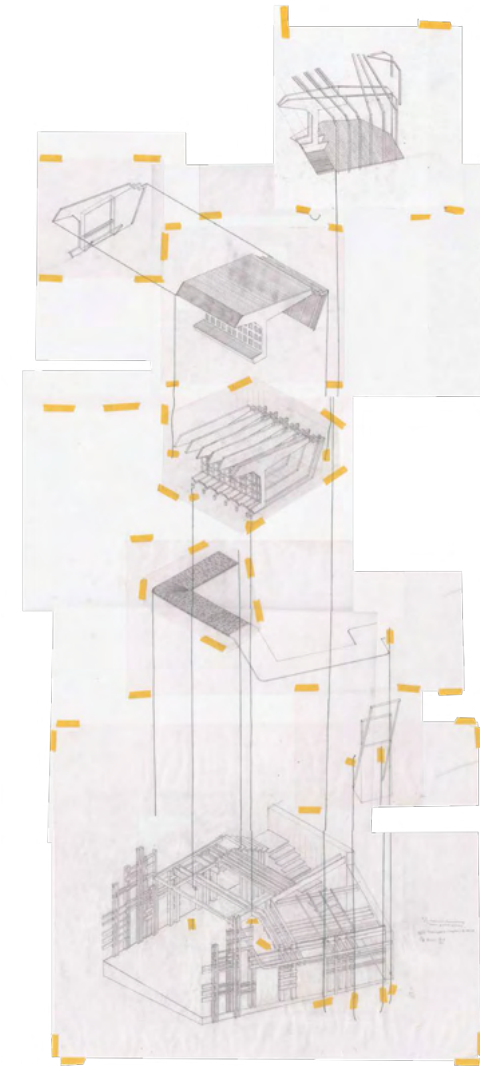
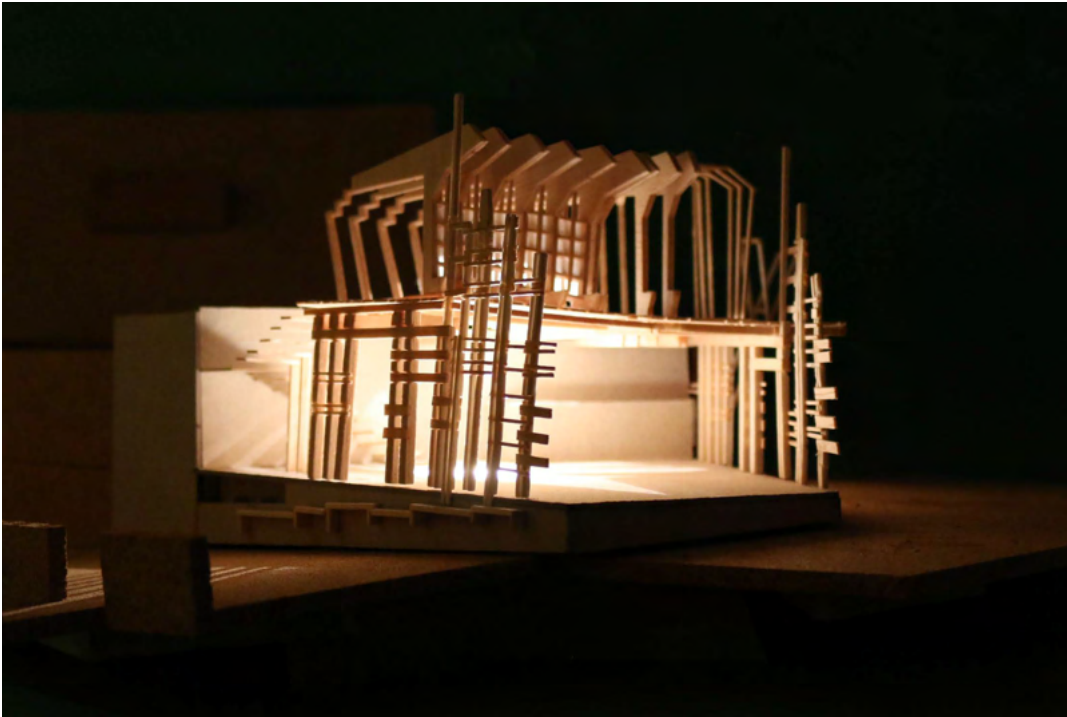

'Loom(iere)' - Building proposal - 2020

A public space made entirely of functioning looms, canopies shift overhead and patterns emerge in the 'walls'. The community are encouraged to dye yarn with vegetable waste from the market, to incorporate and 'dress' the building. The screen formed by static threads, at the front of the scheme are projected onto, transforming the street into an open air cinema

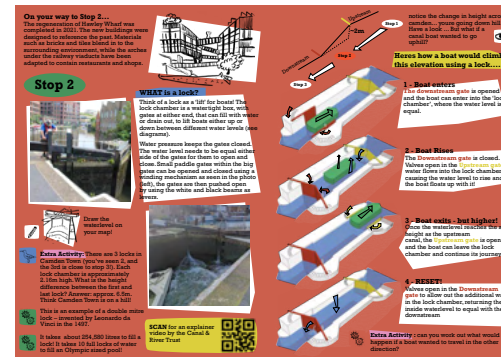
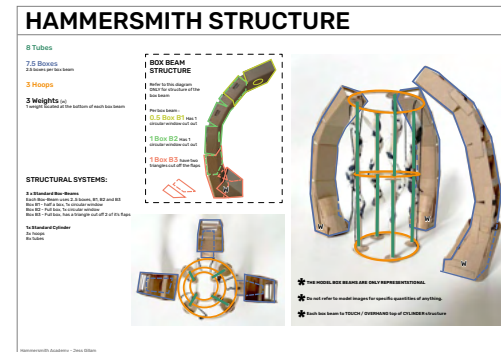

Education Work

Working with Urban Learners, I am a programme developer and workshop lead. Most recently I have been working closely with Camden Highline to develop a series of free workshops, a heritage trail, printed map and open source family and teacher guides, supported by the Heritage Lottery Fund. We recently won a tet award for best programme for a project with Grimshaw Foundation where students from 8 London state schools set their own brief, designed and finally built 1:1 installations at the Royal Albert Hall.

viii. The Contents

Platforms:

Are we actually just practicing polite concealment of civil attention

← See chapter 5

- 5.1 Evidence for common voyeurism
 - Witnesses
 - Familiar strangers
 - Commentary in art

5.2 Paranoia

Destination
Conclusion

← See chapter 7

Journey
Bibliography

← See chapter 8

Carriage
The case for observation and becoming observable

← See chapter 6

- 6.1 Proposition
- 6.2 Observing
- 6.3 Performance of authentic self

Concourses:

Why the Tube is the ultimate space for observing others

← See chapter 4

- 4.1 A snapshot of the city it navigates
 - Diversity
 - Of the times
- 4.2 Implies destinations
- 4.3 Authenticity

Escalators:

The negative implications to society of upholding civil inattention

← See chapter 3

- 3.1 Inequality & attitude to 'other'
- 3.2 Apathy
- 3.3 Individualism
- 3.4 Practicing conformity
- 3.5 Psychological effect

Ticket halls:

Civil inattention & the characteristics of the tube which give rise to it

← See chapter 2

- 2.1 Evidence for it's pervasiveness
- 2.2 Physical & social environments which give rise to it
 - Non-place
 - Transience
 - Architecture
 - Synchronicity
 - Asymmetry
 - Unreliability

Station exteriors:
Introduction

← See chapter 1

← You Are Here

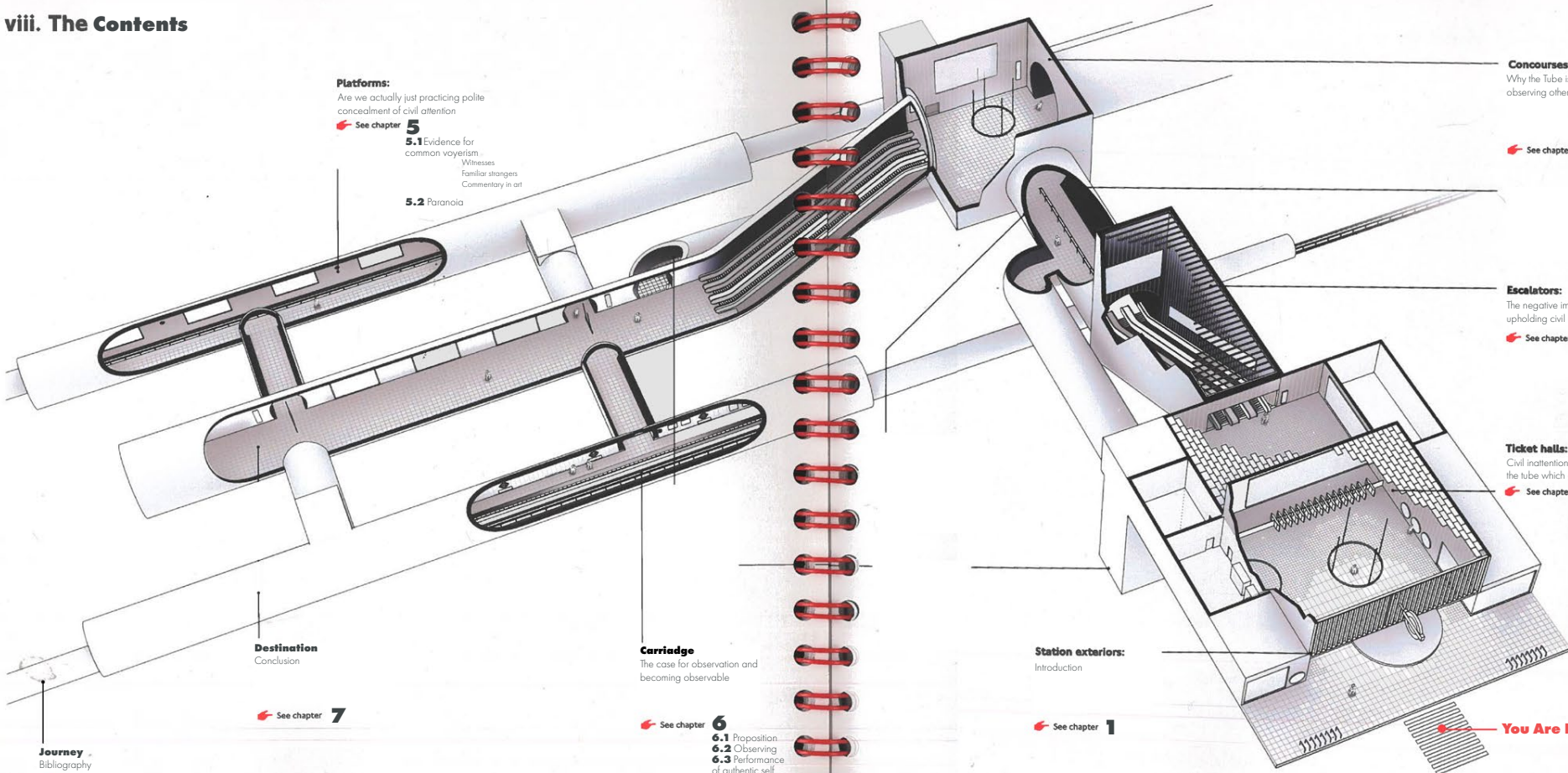

Dissertation Thesis : In Opposition of Ignoring Each Other on the London Underground - Contents Page & examples of page layouts - 2023

My dissertation focused on the tacit rule of civil inattention on the tube. I argued that it's accessibility & unparalleled diversity in the capital, makes it the ultimate public space ripe for social interaction & observation. However, despite its richness in diversity, social stimuli & potential for novel interaction, one of the Tube's most striking features is the way people tend to ignore each other & present as unaware or inattentive to their fellow travellers, creating an atmosphere of disconnection. I then aimed to inspire a dismantling of this tacit rule, suggesting it inhibits social cohesion & a missed opportunity for individual understanding of ones fellow city dwellers. I received a First Class award for this unit based on this piece of cultural research & interrogation.





FURNITURE & FUNCTIONAL OBJECTS

21.06 - 07.07 2024
Mercato Metropolitano
 42 Newington Causeway, London, SE16DR

An exhibition and pop-up, showcasing bespoke furniture and functional objects crafted by a select group of designers and makers.
 With a private view 18:30 - 21:00 on the 21st of June 2024
 Curated by Izzy Watson

If you would like to be featured in future editions of Furniture & Functional Objects, look out for open calls for submissions on @Furniture_FunctionalObjects



Furniture & Functional Objects - Curated show - June 2024

Curated and produced group show 'Furniture & Functional Objects', opened June 2024. I produced all the graphics & copy, organised multiple events surrounding the show & entirely revamped an entire shop into a gallery space. 13 artists were involved. All the signage was fixed with magnets & including hand crafted steel card holders.

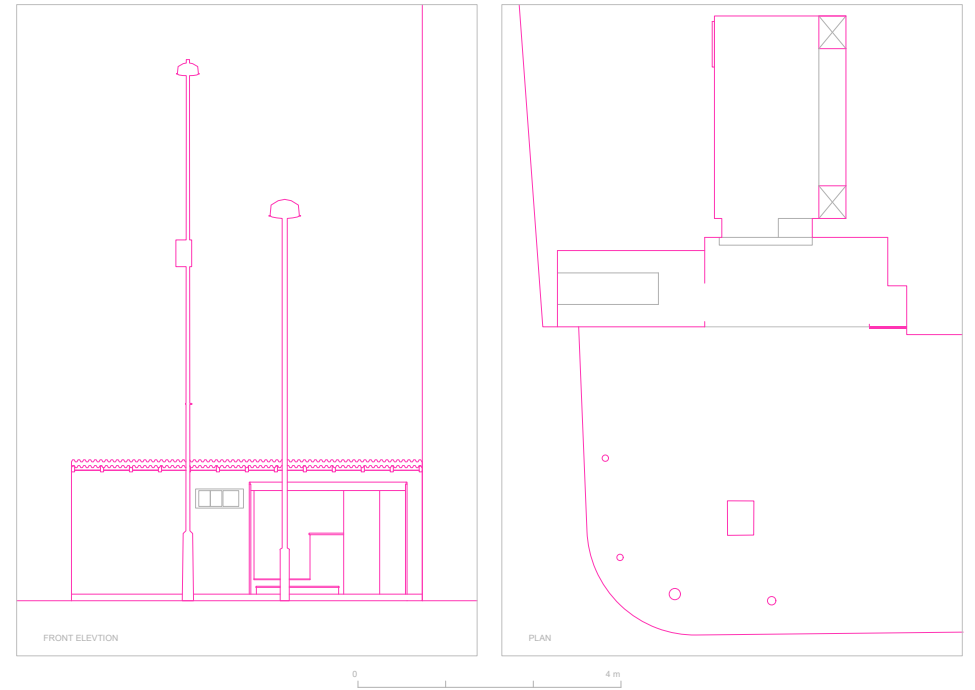

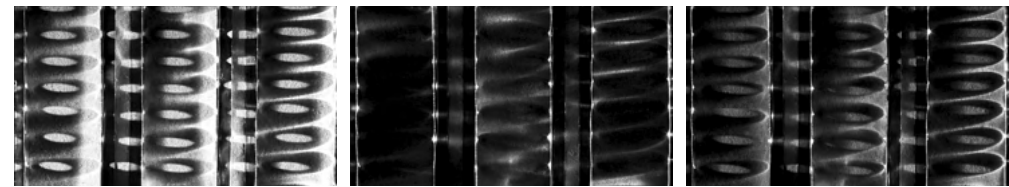
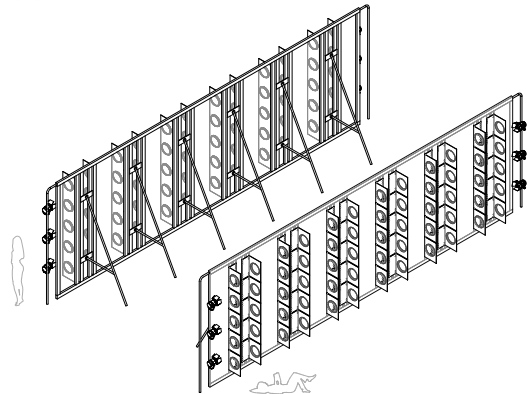
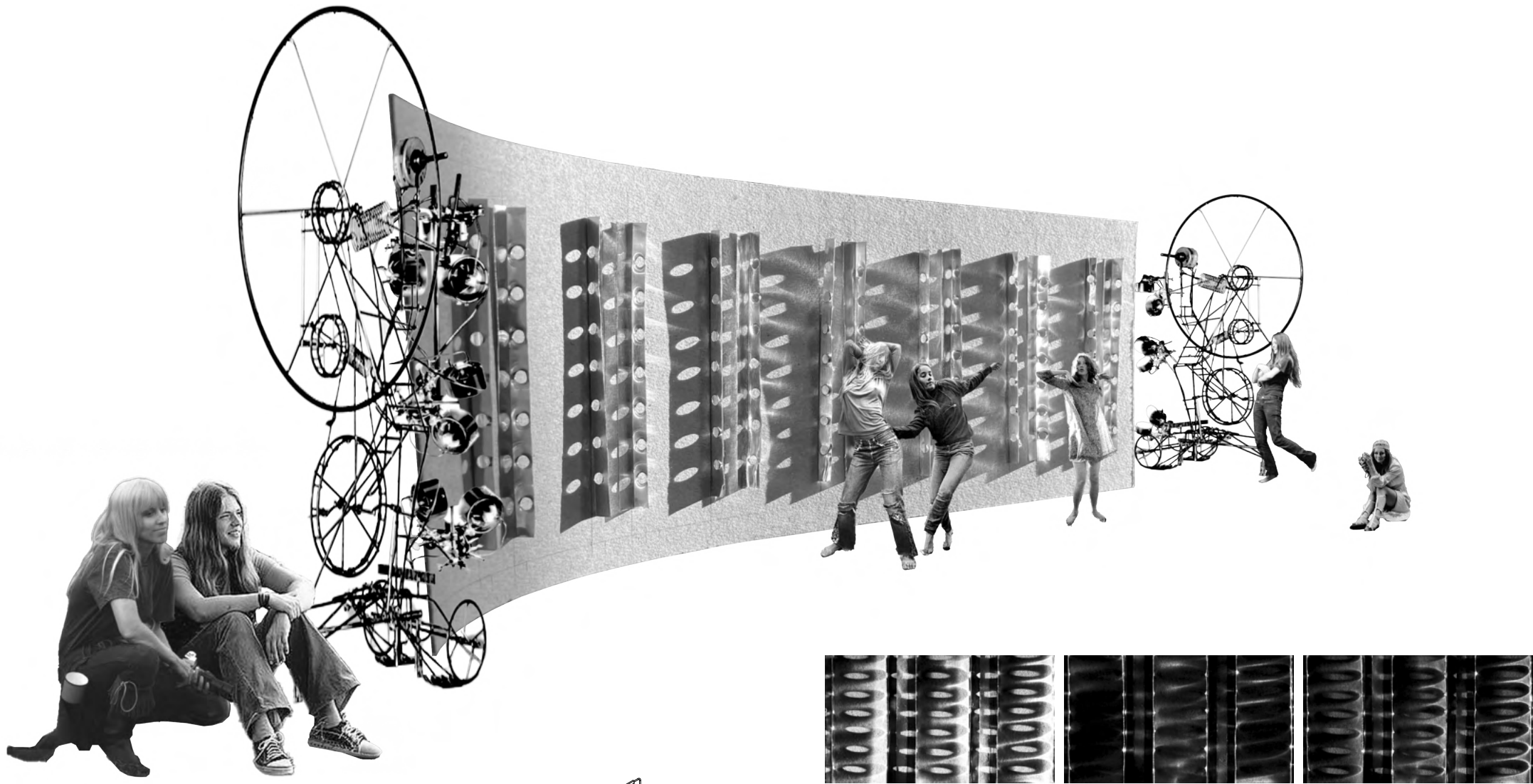

Installation design for festival - 2023-onwards

Continuing with my interest in manipulating metal to create 'textiles' that interact with light. Warp is an activatable structure where by lights move inducing variations in lighting patterns. It would be introduced & demonstrated to the festival goers by a live improvised dance & musical ensemble, able to adjust the lighting rhythmically as they perform. The system can be scaled, but began as a wall structure with bespoke kinetic mechanisms. Extremely difficult and labour intensive to manufacture at scale to be safe.

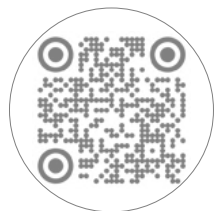

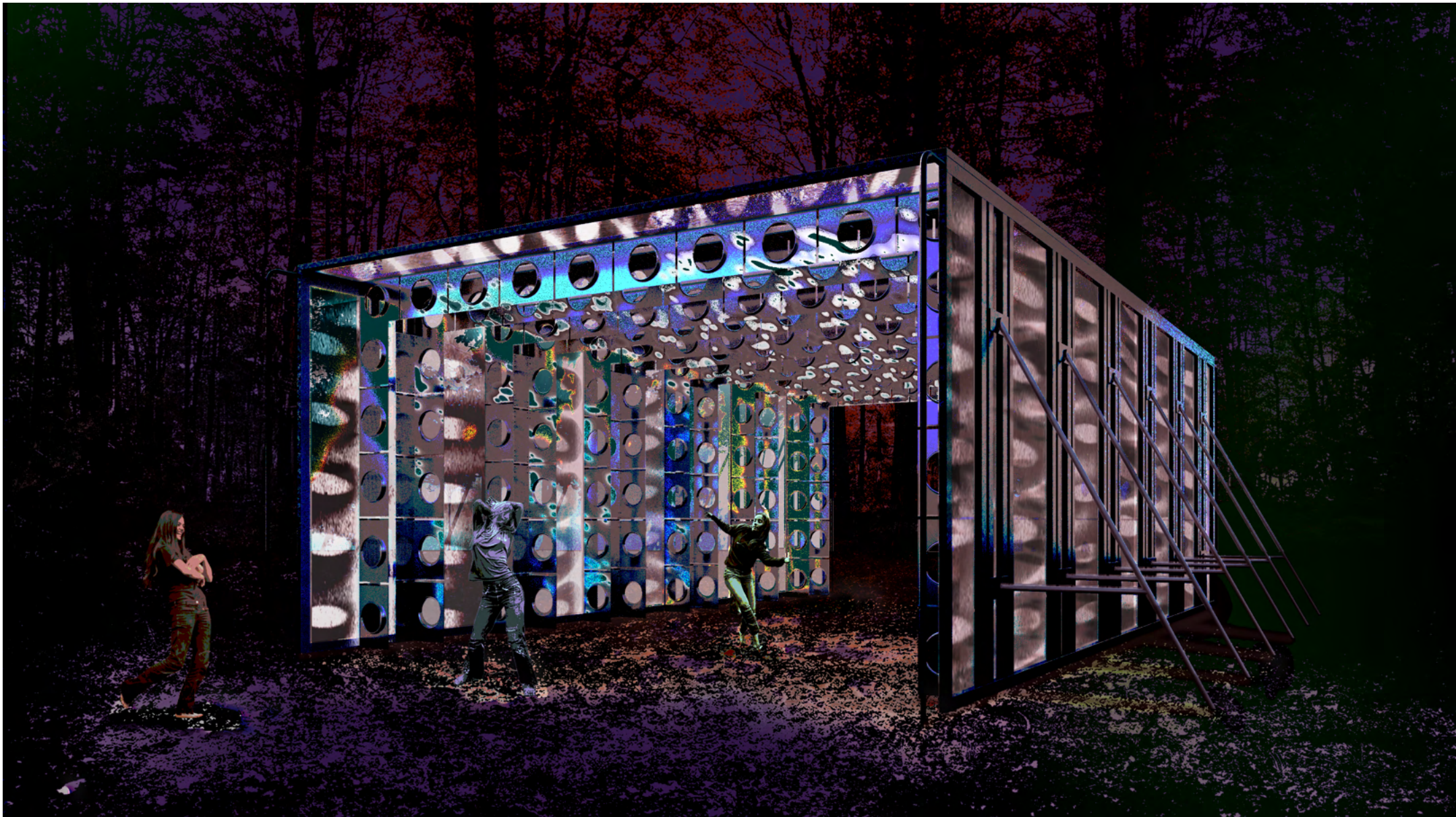

Stage iteration - design for festival - 2023 - onwards

The design exists in various iterations, at different scales and typographies. I continue to develop it and pitch to festivals.

